

# RoHS

- NOTES:
- FINISH:
    - CONTACT: 30u"MIN GOLD PLATED IN CONTACT AREA, 80u" MIN MATTE TIN PLATED IN SOLDER AREA, 50u"~240u" NICKEL UNDERPLATED OVERALL.
    - SHELL: 50u"MIN NICKEL PLATED OVERALL
    - LATCH: 50u"MIN NICKEL PLATED OVERALL
  - MECHANICAL:
    - MATING FORCE: 5-20N.
    - UNMATING FORCE: 8-20N AFTER 10000 CYCLES:6-20N
    - DURABILITY: 10000 CYCLES
    - OPERATING TEMPERATURE: -40°C~+85°C
  - ELECTRICAL:
    - CURRENT RATING:5A FOR VBUS PIN;
    - DIELECTRIC WITHSTANDING VOLTAGE 350/0.1S/0.5mA
    - CONTACT RESISTANCE: 40mΩ MAX
    - INSULATION RESISTANCE: 500VDC/0.1S/100MΩ MIN
  - SALT SPRAY TEST:
    - CONCENTRATION IS 5%, THE TEMPERATURE IS 35±2°C, TEST TIME 48H MIN, NO OXIDATION OR RUST

MATERIAL	Pb	Hg	Cr <sup>6+</sup>	PPB	PBDE	Br	Cl	Cd
LIMIT	<400	<400	<400	<400	<400	<400	<400	<30

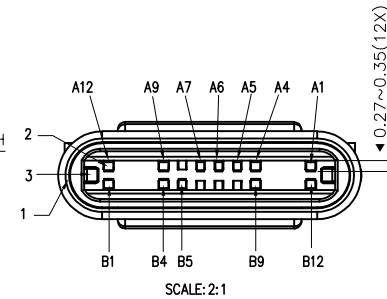
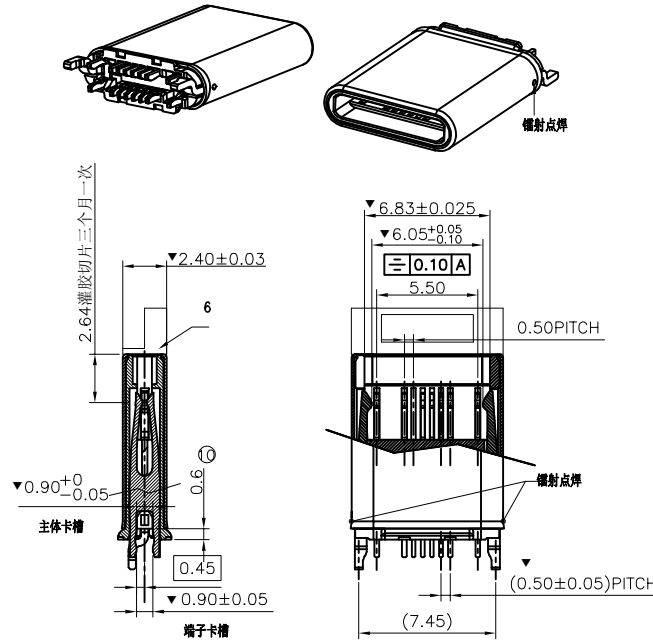
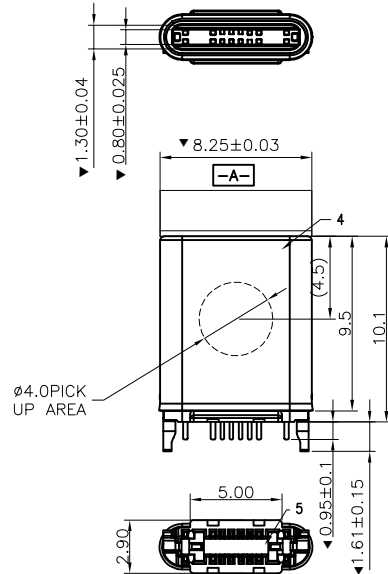

TABLE :PIN DEFINE

PIN	SIGNAL NAME	PIN	SIGNAL NAME
A12	GND	B1	GND
A11		B2	
A10		B3	
A9	VBUS	B4	VBUS
A8		B5	VCONN
A7	Dn1	B6	
A6	Dp1	B7	
A5	CC	B8	
A4	VBUS	B9	VBUS
A3		B10	
A2		B11	
A1	GND	B12	GND

NO	名称/品番	数量	材质	规格
6	CAP	1	LCP+30%GF	UL94V-0, NATURE
5	INSERT MOLDING	1	LCP+30%GF	UL94V-0, BLACK
4	SHELL	1	SUS316L	50u" MIN. NICEKL
3	LATCH	1	SUS301 T=0.4mm	50u" MIN. NICEKL
2	TERMINAL	12	C7025	30u"Au
1	HOUSING	1	PA10T	UL94V-0, SEE P/N

UNITS	SCALE	REV.	SHEET	深圳市创勤科技有限公司 SHENZHEN CHUANGQIN TECHNOLOGY CO., LTD.			
mm	1:1	B3	1 OF 1	TITLE			
 GENERAL TOLERANCE X. ±0.25 X.X ±0.20 X.XX ±0.15 X.XXX ±0.001 X.X* ±5° X.XX* ±2°				DATE		2017.04.15	
				DR.		LIN YUN	
				CHK.		LI JY	
				APPD.		ZHANG	
				DWG.NO.		CQ013-TMLS1200009	
				PART NO.		SEE TABLE	
				FINISH		SEE TABLE	
				SIZE		A4	