

RoHs

无弹片规格

VER	MARK	PR. BY	ECR/ECN DESCRIPTION	DATE
A		LINYUN	新增无弹片规格专用图	11/15' 19
B		LINYUN	新增一款短脚规格	12/23' 19
C		LINYUN	新增端子材质C18400 镀金30U规格	01/08' 21

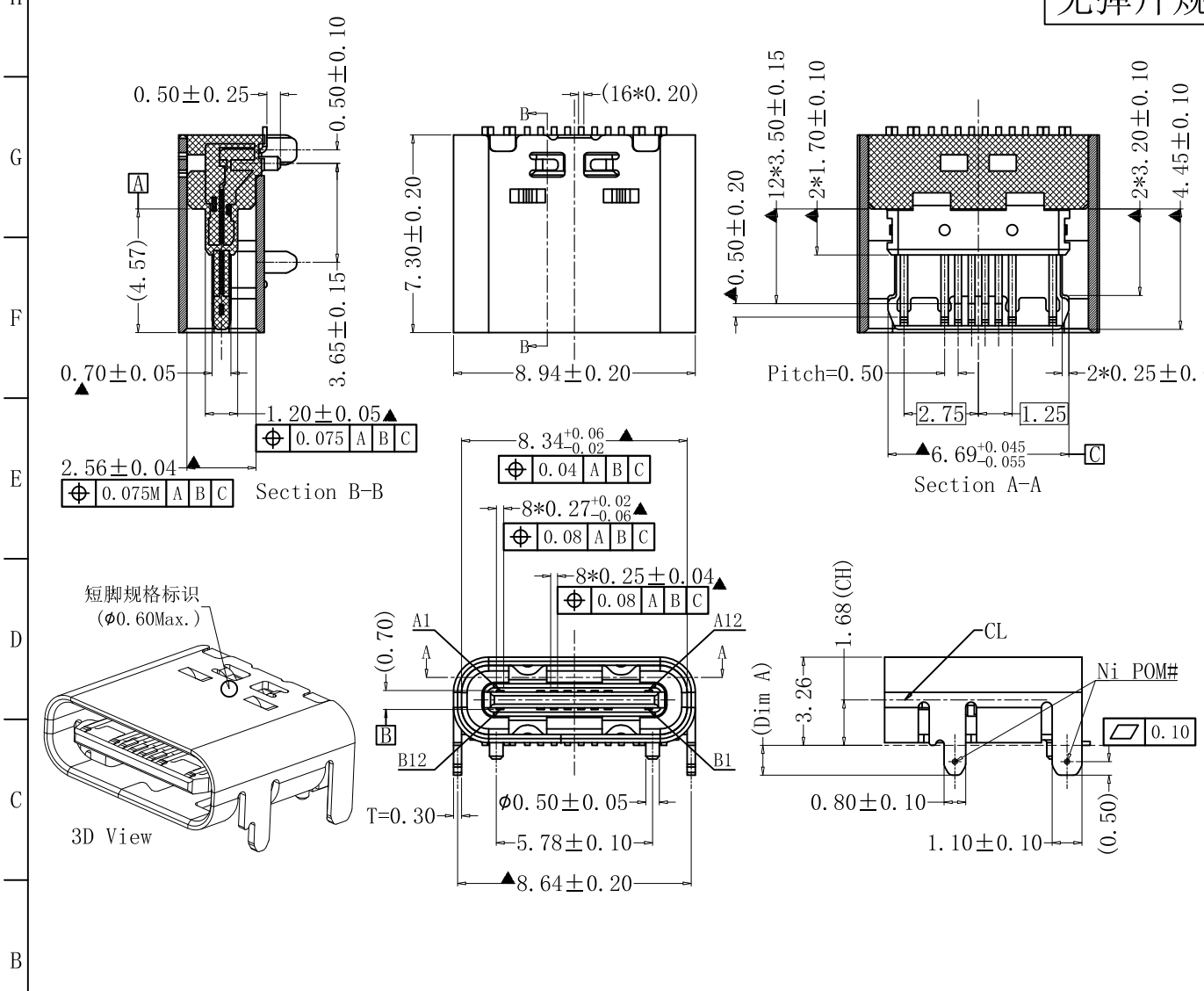

- SPECIFICATION:
- Material & Finish: See the list;
 - Mechanical:
 - Mating force: 5-20Nf;
 - Unmating force: Initial: 8-20Nf; Final: 6-20Nf;
 - Durability: 10000 Cycles;
 - Electrical:
 - Current Rating:
 - VBus Pins: 5A, Vconn Pin: 1.25A, Other Pins: 0.25A;
 - Voltage Rating: 20V Max.;
 - Dielectric Withstanding voltage: 100Vac, 60S, 10mA;
 - Contact resistance: 40m Ohms Max.;
 - Insulation Resistance: 100M Ohms Min.;
 - Environmental:
 - Operating temperature: -40° C ~ +85° C;
 - Salt Spray Test: 48H Min. (No oxidation or rust);
 - Wetting Temperature: 265±5° C, 5±0.5s

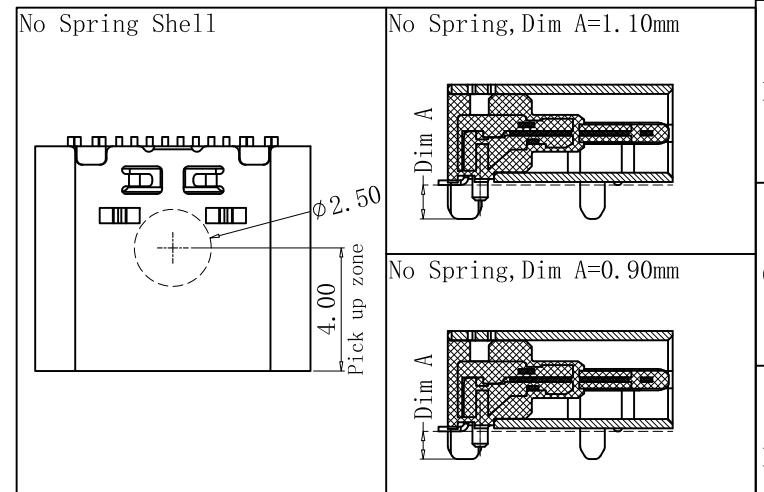

A	NO.	PART NAME	Q' TY	MATERIAL	FINISH	CUSTOMER		GENERAL TOLERANCES UNLESS SPECIFIED		APPROVED BY: ZHANG	深圳市创勤电子有限公司 SHENZHEN CHUANGQIN ELECTRONICS CO., LTD.	
	5	Shell	1	SUS304-1/2H, T=0.30mm	50u"Ni Min.			SIZE	UNITS	X±0.50	X'±5.0'	CHECKED BY: LIJY
	4	GroundBar	1	SUS301-1/2H, T=0.15mm	No Plating	A4	MM[INCH]	.X±0.35	.X'±3.0'	DESIGN BY: LINYUN	DWG NO.:	SHEET
	3	Down Contact	8	C7025 TM04 or C2680H	Au/30u"Ni Min.	SCALE	REV.	.XX±0.25	.XX'±2.5'	CQ013-TFBS1606100	1/3	
	2	Top Contact	8	C7025 TM04 or C2680H	Au/50u"Ni Min.	1:1	C	.XXX±0.15	.XXX'±2.0'			
1	Housing	1	LCP or PA	UL 94 V-0								

RoHs

无弹片规格

VER	MARK	PR. BY	ECR/ECN DESCRIPTION	DATE
A		LINYUN	新增无弹片规格专用图	11/15' 19
B		LINYUN	增加一个短脚规格	11/15' 19
C		LINYUN	新增端子材质C18400 镀金30U规格	01/08' 21
D	△		新增料号	27/08' 21

RECOMMENDED PCB LAYOUT

TOP VIEW, TOL ± 0.05mm

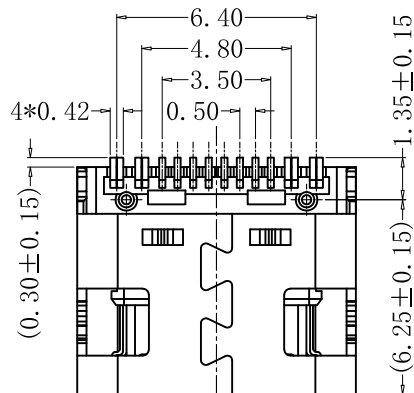
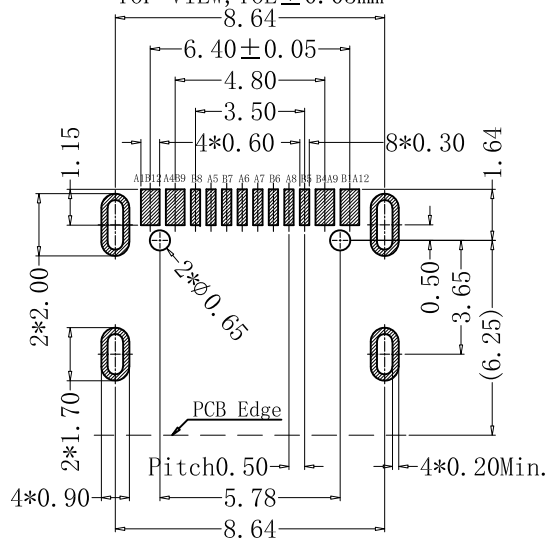

PIN DEFINE TABLE

PIN	SIGNAL	PIN	SIGNAL
A12	GND	B1	GND
A11		B2	
A10		B3	
A9	VBUS	B4	VBUS
A8	SBU1	B5	CC2
A7	Dn1	B6	Dp2
A6	Dp1	B7	Dn2
A5	CC1	B8	SBU2
A4	VBUS	B9	VBUS
A3		B10	
A2		B11	
A1	GND	B12	GND

CUSTOMER		GENERAL TOLERANCES UNLESS SPECIFIED		APPROVED BY: ZHANG	深圳市创勤电子有限公司 SHENZHEN CHUANGQIN ELECTRONICS CO., LTD.	
SIZE A4	UNITS MM[INCH]	X±0.50 .X±0.35	X'±5.0° .X'±3.0°	CHECKED BY: LIJY	PART NO.:	TITLE: Type-C 16Pin 3M 板上型L7.3母座
SCALE 1:1	REV. C	.XX±0.25 .XXX±0.15	.XX'±2.5° .XXX'±2.0°	DESIGN BY: LINYUN	DWG NO.:	SHEET 2/3

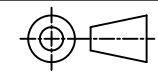

RoHs

VER	MARK	PR. BY	ECR/ECN DESCRIPTION	DATE
A		LINYUN	新增无弹片规格专用图	11/15' 19
B		LINYUN	新增一款短脚规格	12/23' 19

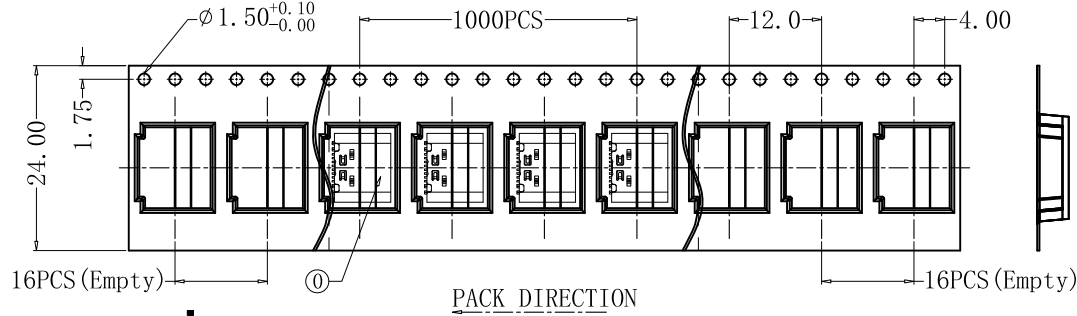

无弹片规格

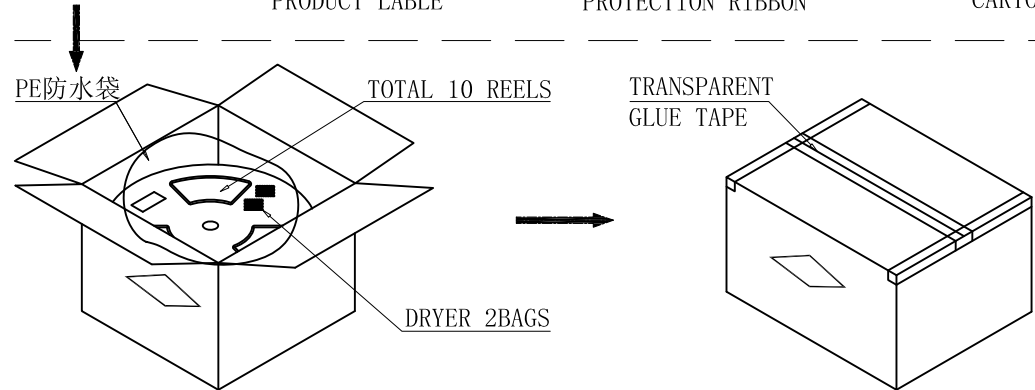
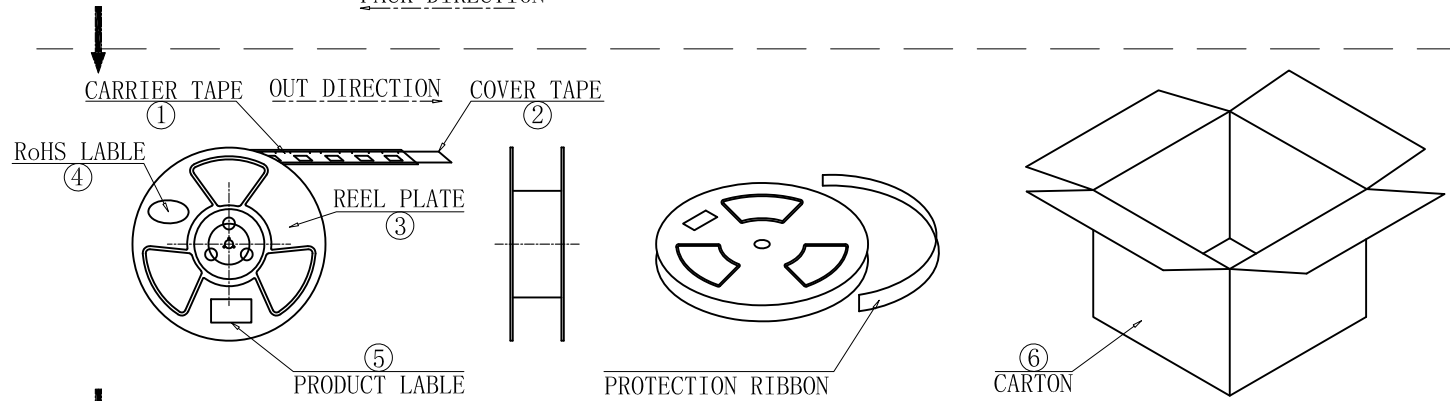

说明:

1. 每卷前后各空16PCS, 尾部用美纹胶纸封住;
2. 将产品放满盘后, 再卷一圈保护带, 用美纹胶纸将其封住, 并贴上1Pcs物料标签;
3. 每10卷盘一叠共10000Pcs并装入1个外箱内;
4. 在搬运过程中要轻拿轻放;
5. 在运输中不可堆放过多(1.8M最高), 不可重压;
6. 跌落测试条件:
成品箱从1.2米高度自由落体(一角三棱六面):
a. 产品不可跑出下带凹槽;
b. 产品不可有摔伤, 变形;
c. 内包装材料不可严重破损.

NO.	NAME	SPEC	Q' TY
①	TYPE C RECEPTACLE		10000PCS/CARTON
②	CARRIER TAPE	W=24mm, T=0.35mm	1000PCS/PLATE
③	COVER TAPE	W=21.5mm	10PLATES/CARTON
④	REEL PLATE	□330*100*24.4mm	10PCS/CARTON
⑤	RoHS LABEL		10PCS/CARTON
⑥	PRODUCT LABER		10PCS/CARTON
⑦	CARTON	350*340*310mm	1PCS/PACKAGE

PACKAGING		GENERAL TOLERANCES UNLESS SPECIFIED		APPROVED BY: ZHANG	深圳市创勤电子有限公司 SHENZHEN CHUANGQIN ELECTRONICS CO., LTD.		
SIZE A4	UNITS MM[INCH]	X±1.0 .X±0.50	X'±5.0' .X'±3.5'	CHECKED BY: LIJY	PART NO.:	TITLE: Type-C 16Pin 3M 板上型L7.3母座	
SCALE 1:1	REV. 1	.XX±0.30 .XXX±0.15	.XX'±2.5' .XXX'±1.5'	DESIGN BY: LINYUN	DWG NO.:	SHEET 3/3	
					CQ013-TFBS1606100		